

Represented by



ILLING[™]
P A C K A G I N G

Product Specification Sheet

Illing Part#

3052B

5 GALLON BLACK HDPE OH PAIL 90 MIL W/ MHDL FDA APPROVED

Part #: 3052B

Size:	5 Gallon
Color:	Black
Material:	HDPE
Style:	OH Plastic Round Pail
Additional Info:	90 MIL, Metal Handle, FDA Approved
Case Pack:	144 each
Pallet Pack:	144 each



Product Specifications

5.0-Gallon Round Container with Lightweight Cover

Multiple Uses

Dry Products

Product Codes

Container: **R059**

Description: 5.0-gallon round can

Cover: **LWD0**

Description: Lightweight round cover

Features

Gauge: 90 mil.
 Nominal capacity: 5.0 USG / 19.0 L
 Stack performance: 400 lbs.*
 Tare weights: Body: 2.09 lbs. / .95 kgs.
 Cover: .42 lbs. / .19 kgs.

*Note: *Ratings will be reduced with uneven load distribution.*

Specifications with Cover

Dimensions: 12-3/8"D X 14-3/4"H
 Maximum capacity: 5.6 USG / 21.2L
 Tare weight: 2.51 lbs. / 1.14 kgs.

Colors

Standard: White, Black and Natural
 Custom: Available at manufacturer's discretion

Decorating Options

Silk-Screening: 32"W X 8-3/4"H
 Four or six* color offset printing
 Print area: 34"W X 9-1/4"H
 Sleeve or pressure sensitive labeling

*Note: *Where available*

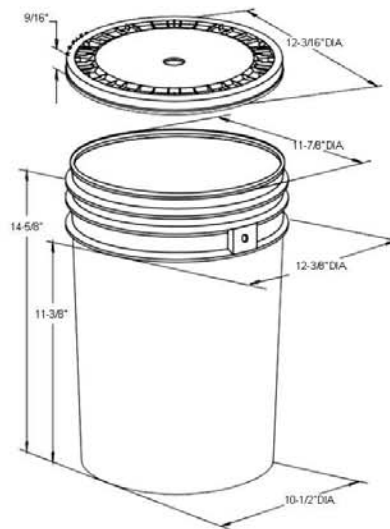

Shipping Data

Qty. per pallet:
 Gross Weight (lbs./kgs.)**:
 Den. (lbs./C.F./kgs./m3):
 Length (in./cm.):
 Width (in./cm.):
 Height (in./cm.):

Bodies

144
 300.9/136.8
 5.7/91.2
 49.3/125.2
 37.5/95.3
 49.5/125.7

Covers

1,728 (36 boxes of 48)*
 725.8/328.3
 7.0/112.2
 52/132.1
 44/111.8
 78/198.1

Filled Containers

36 (12 per layer / 3 layers high)
 Pallet height: 48.8"

Estimated truckload quantity of 6,912 bodies and covers***

*Notes: *Bulk pack also available
 **Weight does not include pallet/packaging
 ***Truckload quantity based on 53' trailer*

Materials

FDA approved materials
 Resin: Body: High-Density Polyethylene (HDPE)
 Cover: High-Density Polyethylene (HDPE)
 MSDS Sheets available upon request

Optional Carrying Handles